

Ford Torque

JANUARY - FEBRUARY 2024



Charlie's 1931 180A Deluxe Phaeton and Phil's 1930 40B Roadster at the Yarra Glen Truck Show

Photo: Charlie Grima

In this issue

Charlie's Museum Club Run.....	7
Yarrambat Heritage Museum Open Day.....	8
A & T Christmas Party.....	10-11
Breakfast on the Yarra.....	14

Technical

The Tale of the F Screw.....	15
Just What Is 600W Oil?.....	16-17
Keeping the Distributor Dry.....	18
Oil Filter You Tube Link.....	21
Split Pins Revisited.....	22



MODEL A FORD CLUB of VICTORIA Inc.

A000048Y ABN 38 251 342 083

A Chapter of the Model A Ford Club of America (MAFCA)

www.modelafordclub.org

The main aim of our Club is to encourage the purchase, preservation and use of the Model A Ford, relevant literature & technical & historical information.

WHO'S WHO 2024

President:

Greg Rose & Leah Young
0417 582 414
greg301@bigpond.com

Vice President:

Kevin & Erica Churchill
0412 802 177
28tudor@protonmail.com

Treasurer:

Peter Churchill
0422 265 555
1929modelatudor@gmail.com

Secretary:

Rob & Sue Rush
(03) 9457 1377
srush38@bigpond.net.au

Committee Members:

Russell & Gillian Boyle
0488 246 070
rbrustya14@gmail.com

Mark & Elizabeth Dohrmann
0419 347 436
mark@ergonomics.com.au

Brenda Smith
0407 889 927
warbrapark@gmail.com

Mark Wallington
0408 551 306
wallo@netspace.net.au

Non Committee Positions

Webmaster:

Mark Apterman
Mark.apterman@gmail.com

AOMC Delegates:

Rob Turner
Kevin Churchill

Library & Club

Merchandise:
Sue Rush (03) 9457 1377

Editor: Kevin & Erica Churchill 0412 802 177

editorial contributions to:
75fordtorque@gmail.com or
P.O. Box 72 Bittern Vic 3918

Club Permits:

Brenden Wolfe & Lualla Tong
0409 145 282
brendenwolfe123@gmail.com

See box at right

Life Members:

Kevin Churchill 2011
*Bob Fretwell 2018
Ron MacDonald 2018
*Bill Mayberry 2018
Rob Griffiths 2021
Joan Griffiths 2021
Faith Hayhow 2021

* In Memoriam

The Model A Ford Club of Vic. Inc. was founded in 1975 as the Model A Restorers Club (Aust) Vic Branch and changed its name to Model A Ford Club of Vic in 1982. We have hosted National Meets in Echuca 1982; Wangaratta 1988; Wodonga 2000 and Launceston 2010. Members possess a wide range of Model A Fords of both Canadian and U.S. of A. origin including some rarer examples of the marque.

We meet bi-monthly in the Phyllis Hore room at Kew Library — see page 3 for details.

CLUB PERMITS

The Club will sign permits for Ford vehicles manufactured between 1918 and 1948. NEW permits require a current road worthy certificate.

Send Permit applications & renewals to:

Brenden Wolfe
45 Hacketts Creek Road
Three Bridges 3797

and include a stamped, addressed envelope for onforwarding to VicRoads or return to you.

Other signatories are Russell Boyle; Peter Churchill & Brenda Smith whose details are at left.

CORRESPONDENCE

Please address all non permit correspondence to: The Secretary
P.O. Box 72 Bittern 3918 OR
srush38@bigpond.net.au

AFFILIATIONS

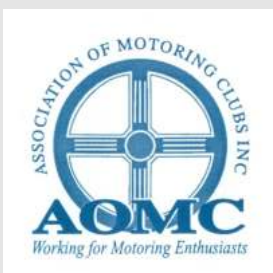

All information & views expressed in Ford Torque are the opinions of the writers & do not necessarily represent the views of the Model A Ford Club of Victoria Inc. Authors of articles provide their suggestions and opinions as general information only and they, the Club and the Club Committee cannot be held responsible for any liability arising from your decision to follow up their suggestions.

LOOKING FORWARD

Club meetings are held bi-monthly in the odd months. Meetings are on the FIRST Wednesday evening EXCEPT January which is usually the LAST Wednesday, at 8.00 p.m. SHARP in the Phyllis Hore Meeting Room, Kew Library, Cnr. Cotham Road & Civic Drive KEW. Melway 45 D6. NOVEMBER is our AGM



NEXT MEETING
 Wednesday 31st January 2024
 Nibble & Natter and
 Parts Swap Meet - CLEAN PARTS ONLY

PLANNING AHEAD 2023

Club Event	Invitation Club Run	PAGE
-------------------	---------------------	------

JANUARY 2024

31	General Meeting	
-----------	------------------------	--

FEBRUARY

3	Berwick Swap - Arkoona Park Berwick	
17	MAFCV Members Only Social Day & Swap Meet with a Free Lunch	3

MARCH

6	General Meeting	
10	Yarra Glen Swap - VDC	5
17	All Ford Day Geelong	
23	Visit to Henry's in Bacchus Marsh Further details in next issue and	
24	Kalorama Rally	5

APRIL

26-28	Florence Thomson Tour	
-------	-----------------------	--

MAY

21	National Motoring Heritage Day	
27-28	Historic Winton	

JUNE

TBC	Rose Cottage Presentation Day	
------------	--------------------------------------	--

MAFCV MEMBERS ONLY SWAP MEET & SOCIAL DAY SATURDAY 17 February 2024

Model A Parts only

This is a social day and swap meet with a FREE lunch all on a private property.

Even if you are not looking for parts please come and join this fun day.

RSVP IS VITAL for catering purposes and we will let you know the address when you RSVP

RSVP to

Kevin Churchill

0412 802 177 or

28tudor@protonmail.com

Thank you to the following contributors to this edition:

- Richard Miles; Russell Boyle;
- Rob & Joan Griffiths; Charlie Grima;
- John Simpson MAFCGB; Paul Hunter;
- Happy Begg, Palmetto A's;
- Colin Lawson.

President's Message



Hi everyone, first time President here!

I'd like to start by thanking everyone for the messages of support for putting my hand up for this - it's a bit daunting but exciting as well. If you don't know me, I've been in the Club for about five years now. So kind of new to Model A's, but I've built a Speedster, owned a Roadster, and I'm about to get a Tudor to play with. So in about 10 years I'll be on-track to have owned every model. Well maybe in my dreams! The Speedster and Roadster are gone, so it's going to be a one-car garage for a while!

The Christmas party was well attended with equal number of Model T and A's. Thanks for the many donations and great prizes. And a big thank you to Henry's Model T & A Parts for their generous gift vouchers. By the time you get this mag the annual Breakfast on the Yarra would have been held - I'm sure we all would have had a good time!

We've had one committee meeting since the AGM and there's a few interesting things on the horizon. Cruden Farm is on the 21st of Jan - there's been a few emails sent out already. Berwick Swap is on the 3rd of Feb, and we're hoping to have a date in Feb for the Model A Club Swap. These have been great in the past so not to be missed! Coming up on the 10th of March is the VDC Yarra Glen Swap, and the 24th of March is the Kalorama meet. Keep an eye out for more events which are still in the planning stage. We'll let you know as soon they're confirmed.

We're hoping to have more events with the Model T Club this year. It's nice seeing them at the Christmas party, and they're a great bunch of people with some awesome cars too!

Hope you all had a enjoyable Christmas and relaxing New Year. Now it's time to get into your garages or sheds and fix those cars, or just go for a drive to enjoy the unique experience of driving a Model A!

Greg

Greg Rose



New Members

Robert & Sandra DOHERTY, Colac. 1930 Coupe
Mark GRUBERT, Kalimna. 1928 Roadster Pickup
1928 Fordor Sedan

2024 FORD TORQUE DEADLINES

Note: Please observe deadlines as it makes the job easier for everyone. Late items may be held over. Ed. Photos, articles, hints etc. always welcome to: 75fordtorque@gmail.com

March-April 2nd February; May-June 5th April; July-August 2nd June;
September-October 2nd August; November-December 4th October



Boiling Point

Humour collected by
Russell Boyle

OLD FRIENDS

Two elderly ladies had been friends for many decades. Over the years, they had shared all kinds of activities and adventures. Lately, their activities had been limited to meeting a few times a week to play cards.

One day, they were playing cards when one looked at the other and said, "Now don't get mad at me... I know we've been friends for a long time, but I just can't think of your name. I've thought and thought, but I can't remember it. Please tell me your name."

Her friend stared at her. For at least three minutes she just stared and stared at her. Finally she said, "How soon do you need to know?"

COMING EVENTS - MARCH 2024

Yarra Glen 2024 Swap Meet



Automotive Parts & Accessories

Garagenalia - Collectibles
Show & Shine

Vintage and Pre-War Cars

Sunday 10 March 2024

Yarra Glen Racecourse - Armstrong Grove, Yarra Glen Vic

Gates Open

Sellers 6:30am - Buyers 7:30am - Show n Shine 8:00am

Site Fees - from \$25

Entry - \$10 (children u12 free)

Gates Close 3:00pm

The Vintage Drivers Club

www.vintagedriversclub.com.au

Site Booking & Enquiries - yarraglenswap@vdc.org.au or Iain 0473 832 277



RACV

66th KALORAMA RALLY

Sunday 24th March 2024



Kalorama Memorial Reserve

Mt Dandenong Tourist Road

For Further Information:
Iain Ross: 0409 027 392
John Lakeland: 0429 101 166

Featuring Cars of the Roaring 20's

- One of Melbourne's pioneering Motoring Events. Running since 1956.
- Vehicles prior to 1990 eligible for Mystery tour and display on the oval.
- Mystery Tour commencing at the Manhattan Hotel 9.00 am for a 9.30 start.
- Vintage & Post Vintage Motor Cycle Clubs Displays, Vehicle Awards.
- Display of Vintage Fire Pumps and Agricultural Machinery.
- Kalorama CFA Kiosk with a variety of food and drinks.
- Drivers under 25 in an eligible car admitted free.



Supported By



www.vintagedriversclub.com.au/KaloramaRally

General Public Welcome

Opens @ 10am.

Entry: \$10.00 per Person

Programs: \$2.00

Children Under 16 Free



All Proceeds to The Kalorama CFA

CLUB AWARDS

The Frank Smith Memorial Award -

is an encouragement award presented to a Member:

- (i) for any particular achievement or assistance given by that Member;
- (ii) who is restoring an A, but is not finished;
- (iii) who has finished restoring their A.

The decision is made by Committee and is based on nominations received from Members, or on Committee Members' observations. Please contact any Committee Member if you wish to make a nomination for this Award. Nominations for 2024 close at the May 1st 2024 General Meeting. There is a Perpetual Trophy and a Keepsake Trophy.

Club Member of the Year. This Award is a Perpetual Trophy and a Keepsake Trophy. It is awarded to a deserving Member from nominations made by Members to Committee, or on Committee Members' observations. The Award is presented at our Winter Lunch Run. If you wish to make a nomination for this Award, please contact any Committee Member. Nominations for 2024 close at the May 1st 2024 General Meeting.



EXPRESSIONS of INTEREST - TOURING to MARYBOROUGH Qld. NATIONAL MEET - 1- 8 September 2024

MARYBOROUGH, the birthplace of P.L. Travers, author of the Mary Poppins series of books, is located on the Fraser Coast Queensland, was founded in 1847, proclaimed a municipality in 1861, and became a city in 1905. Maryborough is a service town for gold mining, wool, timber and sugar. Formerly a busy immigration port it is situated on the pretty Mary River and features a blend of old and modern architecture.

Charlie Grima is seeking expressions of interest to put together a group or groups of Members who are travelling to Maryborough next year for the National Meet.

- ◆ Small group travel is togetherness. Enjoy meals & visit places of interest together;
- ◆ Helps the miles to go faster;
- ◆ Small groups means less disruption to traffic;
- ◆ Major spares can be spread through the group;
- ◆ Half the fun is in getting there!

If you are interested, please call Charlie on

0414 366 235 or email him grimaoldfords@gmail.com



CHARLIE'S MUSEUM & EAGLE ON THE HILL



On a wet and cold Thursday morning seventeen members congregated at the Moorooduc Cool Stores and headed off along some quiet country roads to the Eagle Cafe on top of Arthur's Seat for lunch . The rain started to abate after lunch so we headed down the road to Charlie's Auto museum.

Well, what a gem. Many unusual cars plus memorabilia in every space roof to floor. After many comments " remember mum and dad had one of those " we headed to Charlie's Diner for a refreshing cupper and nibbles . Thanks to Charlie for allowing us the use of their well equipped kitchen. Photos & text - Russell B.

Those attending were:

Charlie, Linda Grima & Linda's sister Wilma
Tony & Shirley Howard
Barry, Liz Houghton & daughter Susan
Mark Apterman
Peter Churchill

Rob & Sue Rush
Rob & Joan Griffiths
Pete Elmore
Russell Boyle
Michael Gerassimou

Birthday Wishes

Happy Birthday to all of our Members celebrating a Birthday in November or December including:

JANUARY: 6th Joan Wilson; 8th Barry Houghton; 19th Peter Mc.Mahon; Chris Saltmarsh; 20th Joan Griffiths; 21st Rod Wood; 29th Graeme Baker; 31st Esko Oinonen; Scott Wilding.

FEBRUARY: 1st Tony Howard; 3rd Brian Skewes; 7th Elizabeth Russell; 13th Robyn De Vries; 14th Robert Balfour; 15th Glenda Chivers; 29th Louise Miles.

Yarrambat Heritage Museum Open Day 2023

Text by Casey. Photos Charlie Grima



John Huitt's Model T Coupe

YARRAMBAT - probably only the locals know where it is. Located just 24km from Melbourne's CBD and close to Whittlesea, the undulating countryside offers views of the Plenty Valley to the west and the Whittlesea Ranges to the north.

Prominent as a gold mining area in the late 1800's, farming became the mainstay after the gold ran out. Now, the farms are being subdivided into hectare lots and large homes are being built.

Each year, we are invited to attend the Heritage Museum Open Day and generally only a few cars turn up. It is a great day with plenty to see and do. Our hosts, the Yarrambat Historical Society do a magnificent job and look after us very well.

Hopefully in 2024, we can make a real day of it and provide more people and cars.



The Rush and Cunningham Model A's

The Yarrambat Heritage Museum is by far the largest project undertaken by the Society. The Society took over the site in early 2001 and over the ensuing years has developed the site into an operational Heritage Museum.

A grant from the Victorian State Government enabled the relocation of the original 1878 Primary School classroom to the site in 2002. The Golden King Mine Battery was dismantled and rebuilt on site in 2002. Around this time a security fence, funded by the Nillumbik Shire Council, was erected around the Site.

Restoration of the Len Young Woolshed was carried out during 2005-6. Work on all four buildings on site is ongoing.

BENDIGO SWAP MEET 2024

Photos Russell Boyle



Good weather with Saturday being the busy day, tapering off later in the day due to very warm weather. A lovely casual dinner at the White Horse Hotel.

We were able to distribute a dozen or so new membership packs to Model A owners.

Russell B.



The 2024 Swap Meet was the first one for 4 years, so everyone was excited about this one. Organisation could have been better but that will come with practice. Our sites on the oval had a steady flow of visitors and passers by inspecting our wares. We did sell some items but Rob would have liked to take less home than he did.

A happy band of members and friends enjoyed a delicious meal at the White Horse Hotel. See you next year at sites 1396 & 1397. Casey

A & T CHRISTMAS PARTY 2023



'28 A Tourer, 1930 A Coupe & '31 Two Door Phaeton.



Phil looking happy with his raffle prize.



'28 Tourer, '30 Coupe & '28 Tourer

Photos: Russell Boyle

A & T CHRISTMAS PARTY 2023



A wonderful day was had by all who enjoyed the Christmas treats, the extensive raffle table and the camaraderie. The T Models won the cup again - they have a few to catch up on. It's all good fun and helps to get the numbers up.

Photos: Russell Boyle



**Meeting Notes of the AOMC
Delegates Meeting Monday
November 20th, 2023 at 7.30pm
Venue: Austin Healey/Jaguar Clubrooms**

There were 87 attendees representing 67 clubs and 1 visitor (Guest Speaker).

Chair: Keith Mortimer, President AOMC

Minutes of the August meeting were accepted on a motion moved Daryl Meek (Goldfields CC), seconded Damian O'Doherty (Vintage & Classic CC Ballarat) and carried.

Presidents Report: American Motoring Show held yesterday was a good day with approx. 450 cars in attendance. A lot of work from AOMC committee, particularly Iain & Maureen Ross, Howard Billing, Mark Fenton and Philip Johnstone. Reward for Keith was wandering around and seeing the young families in attendance.

VicRoads working party met via zoom last week, with Keith (AOMC), Neil Athorn (VicFed) and 3 VicRoads representatives. Issues raised were license plates, illegal CPS usage, renewal issues, conditions on permits and inconsistencies around M & H plates. Further meetings will be scheduled.

Coming AOMC Events:

* **Festival of Motoring – Sunday 21 January 2024 at Cruden farm.** Closing date for entries is December 15.

* **Aussie Car Show – Sunday 4th February at Mornington Racecourse.** Iain Ross encouraged the Australian make clubs to support this show.

* **RACV British & European Motoring Show – Sunday 18th Feb at Yarra Glen Racecourse.**

* **Florence Thomson Tour – 26th to 28th April.** Based around Traralgon and touring the Gippsland region.

* **National Motoring Heritage Day – Sunday 19th May 2024.** Looking to support various events around the state.

Treasurers Report. Mark Fenton, AOMC Treasurer, apologised that he did not have the quarterly report with him as he had concentrated on the annual report. He reported that several clubs are yet to renew subscription.

AMHF Survey. Has been completed with around 6,000 respondents. Data is being processed.

Engine number records. Philip Johnstone reported that demand continues with various makes being submitted, including Toranas, Monaro, EH Holden, Ford Gt, Falcon, Land Rover and 5 Lancias.

Delegates reports / General business:

Peter Paproth (FX-FJ CC) – Noted that the state titles were held recently in Ballarat, and it was pleasing to see the next generation of young kids coming into the movement. Director of the event was a young woman in her 20s.

Rick Cove (EGHVC) – Rick noted that he attended the Ballarat Delegates meeting via zoom, and although he could hear everything, he was not able to make a comment. Similar thing happened with the taxation seminar.

Ian Clarke (Dandenong Valley CC) - Reported that the 50th anniversary Berwick Swap will take place on February 3rd 2023. Also, the club is revising the Australia Day Car Show with an event being held in Dandenong on Friday January 26th.

Guest Speaker: Scott Watson – Variety Around Victoria. Scott is the events manager for Variety running the “Variety Bash” and “Rally Around Victoria”. Variety’s main car event is the Bash, but not many people know what happens with the money raised. It helps kids with illness, disability and their families reach their potential. Since the NDIS started, they have aimed at covering those who are not covered by NDIS.

In 2022, \$13.3 million was granted impacting 152,312 kids. 2023 saw a 48% increase in requests for support.

Rally Around Victoria is a 3 year old event that started during covid, as drivers were unable to leave Victoria. It is a 3 day event open to all vehicles and is mainly tarmac based with some small dirt sections. This year’s event starts at Cruden Farm and travels to Waratah Bay, Raymond Island, Bairnsdale, Walhalla, Marysville, Healesville and to Berwick for the finish.

It is limited to 60 vehicles because of the size of the towns they are visiting and staying at.

Keith Mortimer thanked Scott for his presentation and announced a short break for supper at 8.05pm.

Meeting continued as the AGM - see page 13

Meeting Notes of the AOMC Annual General Meeting

Monday November 20th, 2023
at 8.30pm

Venue: Austin Healey/Jaguar
Clubrooms

Treasurers Report: Mark Fenton presented the annual financial report for 2022/23 financial year. Accounting systems and support have been improved, financial standing is good and accounts have been independently reviewed. Total equity as at June 30, 2023 is \$255,728 leaving the AOMC in a steady financial position.

The accounts show a \$7,846 loss for the year, mainly due to the timing of event transactions.

There have been questions about the healthy bank balance of the AOMC. Mark pointed out that some of these funds are held in trust for the RACV for grants to small clubs also, there are liabilities for upcoming events.

A healthy bank balance also enables the AOMC to invest in programs such as the recent AHMF survey, and we are also ready to underwrite a group insurance scheme for clubs.

Shows and events have been good fundraisers in the past, but this has been challenging of late. The great work of Philip Johnstone with the Engine Number Records service has again raised over \$9,000 for the year.

Fees have remained stable, even though they are not covering the day to day running of the organisation, and Mark proposes no change to the fees for the 2024/25 financial year.

The financial benefit to the community from the movement is being measured by AOMC, and clubs are encouraged to provide data re charitable activities that can be put together as general movement contributions.

Notices of Motion:

It was moved Mark Fenton (AOMC, Chrysler Restorers Club), seconded Bill Ballard (F.O.R.D) that the 2022/23 annual financial report be accepted. Motion carried.

It was moved Mark Fenton, seconded Peter Welten (Triumph CC) that the fees for 2024/25 remain unchanged. Motion carried.

Presidents Report: This past year the committee started to look at its purpose. It has come up with the following: **“To support and protect the interests of motoring enthusiasts and our member clubs.”**

The committee has also formed five priority areas,

each with a team leader and a sub committee. These are: **Member Services** – Club advice, Engine Number Records, seminars.

Events & Community Engagement – Events, Shows, Community benefit.

Communication & Enablement – website, social media, newsletter, delegates meetings.

Policy & Research – policy statements.

External Engagement – VicRoads, Dept of Transport, Politicians, Vic Fed, ASRF, Motorsport Australia, RACV, and any other organisation we need to deal with.

Keith then introduced Geoff Hergt (Jaguar CC) to chair the election of office bearers and committee. All position were declared vacant and nominations called for.

Secretary – Tony Hall (Escape Motoring) was the only nomination and was duly elected. **Treasurer** – Mark Fenton (Chrysler Restorers) was the only nomination and was duly elected. **Vice President** – Iain Ross (Bristol Owners Club) was the only nomination and was duly elected. **President** – Keith Mortimer (Jaguar CC) was the only nomination and was duly elected.

It was moved Daryl Meek (Veteran CC) seconded Peter Welten (Triumph CC) that the number of Ordinary committee members be 8. Motion was carried.

There were 5 nominations for committee positions being: Lawrence Glynn (BMW Drivers), Philip Johnstone (TSOA), Peter Matthews (Classic Motorcycle Club), Robbie Mihelcic (Vic Torana Club), and Ken Goodin (Vict. Torana Club). There being no further nominations those 5 nominees were duly elected to committee for 2023/24 year.

Keith Mortimer announced the meeting closed at 9.06pm.

BREAKFAST ON THE YARRA 2023

Photos: Russell Boyle



Breakfast on the Yarra(bank) is one of our "signature" events along with such others as Rose Cottage and the Ford Flathead Festival. Sunday morning dawned bright but with the threat of heavy rain sometime in the day. Any fears of a lack of parking were allayed when we arrived at 8 a.m. to find plenty available.

A very pleasant morning was had by all, with many members carefully watching the weather radar on their phones. By 10.30, most people had left in order to beat the rain home. As always, an excellent event. Casey

THE TALE of the F... Screw

(Which is of course, short for the Focusing -screw)

By John Simpson Model A Ford Club of Great Britain

My 1930 Model A "the old girl" was blowing fuses so my immediate thought was, "Ah, we have a short somewhere".

Now using only Ford parts (thanks Dave O'Neill) I did the following...

Added an extra earth strap from the battery to ground

Rewired from the generator to the starter motor

Rewired from the starter motor to the bulk head

Fitted a new bulkhead terminal box, coil and ammeter

Rewired the wiper motor

AND STILL THE FUSE BLEW

So.... I rewired the lights – again with a Ford wiring loom

Fitted new bulb holders to each light

Added earths to the lights

The light wiring loom included new wiring for horn – and for the hell of it I fitted a brand new horn also

Before the final assembly of the lights it was – ignition on, ready, car running well and all lights working correctly -Fuse not blown- Great!

Next....

I reassembled the lights And

BANG! AGAIN THE FUSE BLEW!!

It was then and only then I realised that everything I had previously done was completely unnecessary.

The issue was the F-ing screw, I had been screwing the focusing screw in too far on the headlight so it was making contact with the bulb holder causing a SHORT How I laughed (NOT)

I did however escape from washing the dishes of quite a few evenings and learnt a little bit more about what makes "the old girl" tick.

Our resident Sparky adds: "Yes, the focussing screw can easily short things. It's an extremely poor design. The picture printed here is from the original service sheets and shows the early headlamp which has no parking light. If you have the later Duolamp type which has an additional 5w watt parking light, here's a tip.... the parking light goes at 12 o'clock, not 6 o'clock – for years I had my reflectors on upside down! I have been told that the modern reproduction reflectors do not have the correct parabola contours so are impossible to correctly focus... well, that's my excuse anyway!" ■

Headlamps

Align and focus the headlamps with the empty car standing on a level surface in front of a white wall or screen 25 feet from the front of the headlamps. This wall must be in semi-darkness, or

sufficiently shielded from direct light for the light spots from the headlamps to be clearly seen. The wall must be marked off with black lines as shown in Figs. 274 and 275.

Details for making the layout are given in Fig. 276.

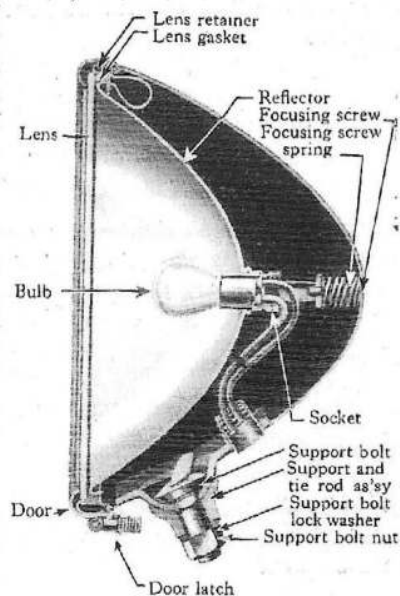

Focussing

Turn the headlamps on "bright" but keep one lamp covered while focussing the other. Adjust the bulb filament to the focal centre of the reflector by means of the screw at the back of the lamp, so that an elongated elliptical spot of light, with its long axis horizontal, is obtained on the wall (see Fig. 274). The bulb should be adjusted to obtain as good a contrast and as well-defined cut-off across the top of the spot of light as possible.

Editor's Notes

1. The Duolamp light referred to is a tail light. The headlight with a parking light bulb is called Twolight
2. Brattons produce a parabolic correct reflector which has "top" marked.
3. The figures referred to are 208, 209 & 210 (pp105-106) in the Canadian Service Bulletins available from our library.

Steering Boxes, Gearboxes and Differentials - just what is 600W oil?

By Paul Hunter North Island Model A Ford Club

600W Oil was used in Model A transmissions, differentials and steering boxes when they were first manufactured. It was the oil weight of Henry's choice and it must have done its job as so many Model As have survived till today. With change in the industry, and with little in the way of a technical specification for the 600W oil and that Henry changed specifications as he developed newer cars, the original 600W oil became harder to find resulting in many car owners using any oil they could find. With these newer oils, people did often notice the puddles underneath their cars but they thought was normal for a Model A. The saying went "If it wasn't leaking it must be empty."

It is a mystery how or why the term "600W" became synonymous with Model A steering-gearbox differential lubrication. The only reference to "600" or "600W" that can be found in Model A Ford literature is on page 377 of the Service Bulletin where they are discussing the seven tooth steering system. On page 375 of the Service Bulletin they recommend M-533 lubricant for the transmission and differential whereas on page 216 Ford recommend simply "gear lubricant."

As Model A's started to go through restoration, it became apparent that the wrong grade of oil was being used. Transmissions and rear differentials were using 90 weight. People were putting grease in the steering boxes. These oils and greases were used in more modern cars. It was assumed new oils meant they were better. There are a number of people and books that have tricks for matching the original type of oil. This includes STP oil treatment with a supplier's version of 600W. Some also warn against these tricks. If you ask other Model A enthusiasts you will get even more suggestions.

Quote "I would prefer using known viscosity oil rather than an oil about which I know nothing. Rather than buy an unknown, I would recommend a quality high pressure gear lubricant for the Model A steering-transmission-differential such as SAE 250 or SAE 140 in that order. SAE 80W-90 is a little

thin for quiet shifting and you will probably hear more transmission and differential noise than with 250 or 140.

Some companies are packaging an 85W-140 oil which is a little thin for our purpose". -- Lyle Meek, Technical Director MAFCA.

Everything I've found indicates 600W was mineral based gear oil, early Model T data talks about 600W Steam Cylinder Oil, which research showed having a viscosity of ISO600/680.

ISO 320 is equivalent to SAE 85W140, ISO 460 is equivalent to SAE 140, ISO 680-1000 is equivalent to SAE 250.

The following are the ISO 600/680 equivalents available in New Zealand:

Mobil: Mobilgear 600 XP 680

BP: Energol GR-XP 680

Fuchs: Renolin CLP Gear Oil 680

Model A Ford Capacities:

Gearbox & Differential add just enough fluid to the differential to bring the level to just below the opening. A good gauge is to insert your little finger to the first joint and it should have fluid on it when removed.

The same goes for the transmission. Remove the filler plug on the side and fill with fluid until it comes up to just below the opening. There is a wealth of information waiting out there. All we have to do is Google it and have plenty of spare time surfing the Internet.

**Disclaimer:*

The above is written following research via the Internet and the information presented is the author's opinion. He would encourage readers to ensure that they undertake confirmation of the above, if changing from their oil/s currently used.

Will I (Paul) be changing - yes, the technical arguments are in favour of the heavier oil. What have I got to lose? Apart from some time and money - nothing.

I believe that it is a well worthwhile exercise. We (MAFCVNZ) have club members using oil weights from SAE 85-SAE250, with everyone having their beliefs about the performance of their oil weight choice. Talk to you fellow club members for their thoughts and views.

PENRITE TRANSOIL 250 PROPERTIES

Transoil 250 is premium Non EP, API GL-1 rated SAE 250 gear oil designed specifically for use in Veteran, Vintage and Edwardian gearbox, Transaxles and selected spur and bevel type rear axles. It does not contain any aggressive load carrying additives that may cause corrosion damage to ferrous and non ferrous metal types used in these types of vehicles.

APPLICATION

Transoil 250 suitable for use in Manual Transmissions and transaxles in veteran, vintage & Edwardian vehicles.

Transoil 250 is suitable for use in rear axles of veteran cars of one, two and four cylinders. It contains a special additive to help the load carrying ability of the oil. Contact with any water or moisture should be avoided or seal degradation may occur. This oil is compatible with leather and Synthetic rubber seals.

Transoil 250 can be used in older style of Hypoid gear sets.

Please Note: While this oil has the characteristics of the old 600W or steam cylinder oils, it **MUST NOT** be used as a steam cylinder oil.

Applications

- Classic - Limited Slip Differential
- Classic - Hypoid Differential

PRODUCT BENEFITS

- Does not corrode ferrous and non-ferrous materials.
- Compatible with leather and Synthetic rubber seals.



READERS' MARKET PLACE

(Minimum number of words 20 for 10/-, then 6d per word. Display panels £1 per inch.)

FOR SALE: All 1931 "A" Model Ford parts. Two gearboxes including clutch assembly £3 ea. Motor plus spares £7. New rear spring £1.10.0. Front mudguards £1.10.0 ea. Steering column £1. Front axle assembly 10/-. Rear cross member 10/-. Luggage carrier 10/-. '34 grille £1. '37 rear spring (new) 20/-. **CONTACT:** Clive Windley, 19 Eumeralla Road, South Caulfield, 58 1178.

FOR SALE: 1948 Ford Mercury sedan, excellent body, black duco, four good tyres, gearbox reconditioned, motor only fair, good interior. Car will be registered for twelve months. Price £125 ONO. Contact Max De Jersey, 15 Keamy Avenue, Cheltenham.

SEVENTEEN

Charlie Grima was looking through an old car magazine dated June 1964 & found this for sale advertisement for Model "A" parts - and look at the prices!! Conversion is 1 pound = \$2

How things have changed.

FOR SALE

1932 Pick-up.

'48 Mercury engine.
3 5/16 Bore. Triple
97's. ¾ Repco Cam.
Adjustable Tappets.

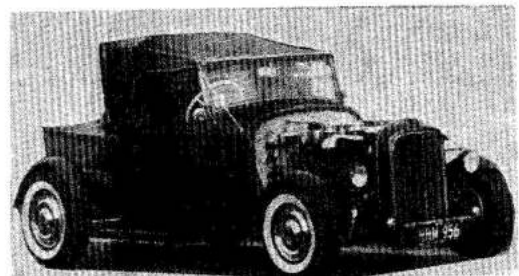

11" clutch, '32 box, 4-11.1 rear eqtd, 13" wheels front, 15" wheels rear, new tyres, tele shocks.

USED FOR EVERYDAY TRANSPORTATION RELIABLY

BEST E.T. 16.54 SECS.

HAGGLING STARTS AT £325

GRAHAM FERGUSON, FLAT 20, 131 KAMBROOK ROAD, CAULFIELD

Tiny Tip - Keeping Moisture Out of the Distributor

By Happy Begg, Palmetto A's South Carolina

Have you ever driven your Model A in the rain, and have it "act up?" This is exactly what happened to me while on tour with the Western Carolina's Model A Club. First the car began to periodically "skip." Then it began to really run rough, until it just died! The cause - moisture in the distributor. Well, this is a common problem in cars without electronic ignitions.

Usually, the humidity level in the atmosphere is something the hot engine "burns" off before coming in contact with our distributors. But, when it rains, there is just too much moisture in the atmosphere and the inside of the distributor cap will begin to "sweat." This in turn causes moisture droplets to fall onto the points, thus interrupting the flow of electricity between the ignition coil and the spark plugs. Generally, if you can get the distributor dry, you can go on your merry way. But how to solve the problem before it happens is the real question. Nobody wants to try to stand in a downpour over a hot engine and try to dry out their distributor!

WD-40 is the answer! It was developed in 1953 by Norm Larson, founder of the Rocket Chemical Company, in San Diego, CA. WD-40, from the abbreviation "Water Displacement, 40th formula," was originally designed to repel water and prevent corrosion. Another little "tool" to keep in your arsenal!

If every 3-4 months you will open up your distributor and spray the underside of the cap and down into the distributor and the tops of the spark plugs and the plug "wires," a rain shower will never leave you sitting by the side of the road waiting on AAA! ~Happy Begg, Palmetto A's of South Carolina

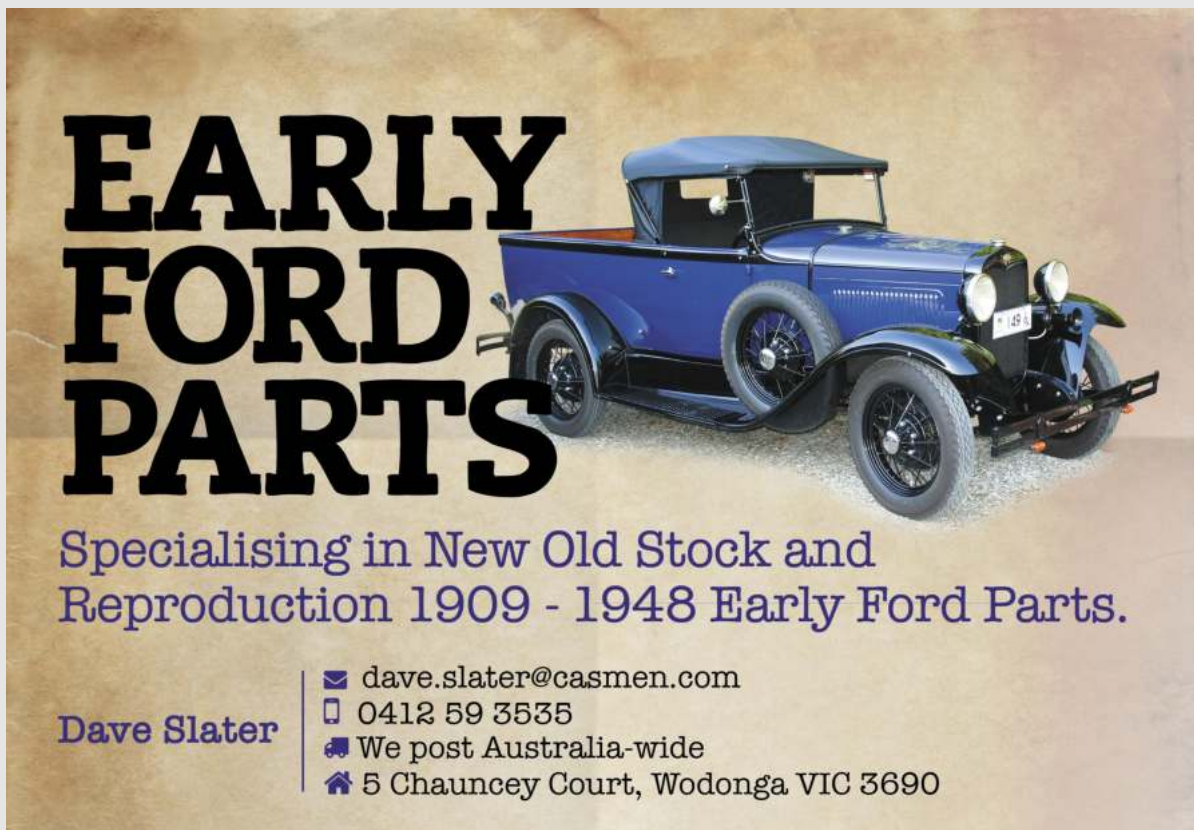

**EARLY
FORD
PARTS**

Specialising in New Old Stock and
Reproduction 1909 - 1948 Early Ford Parts.

Dave Slater

- ✉ dave.slater@casmn.com
- ☎ 0412 59 3535
- 🚚 We post Australia-wide
- 🏠 5 Chauncey Court, Wodonga VIC 3690



Henry's Model T, A & Rod Parts has been serving early Ford enthusiasts for over 40 years supplying parts and accessories for your restoration and hot rod projects.

We also offer servicing, tuning, upholstery, electrical, general maintenance, light fabrication and exhausts for your Model T & A.

Phone: 03 5368 1088

email: sales@henryspares.com.au



www.henryspares.com.au

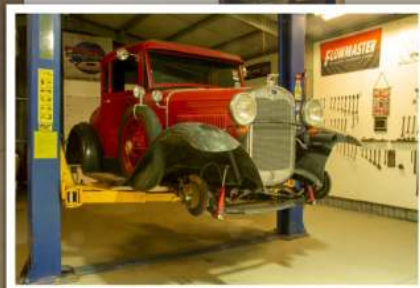

General Meeting Minutes
Wednesday, 1st November, 2023.

Phyllis Hore Room, Kew Library

Phyllis Hore Meeting Room, Kew Library and online via Zoom.
Meeting opened by our President, Robert Turner at 8:05 pm.

Attendees: 34 and 2 via Zoom. Attendees noted on the register.

Apologies: Chris & Sharyn Wells, Geoff Hayhow, Ray and Ann Newell, Bill Bartlett, Gary Mexted, Barry and Liz Hoghton, Merv Swingler, Neville and Pat Seiffert, Peter and Dulcie Lachmund, Peter McMahon and John Aird.

Visitors: Barry Hancock...Model T Ford Club of Vic.

Sick List: Peter Lachmund is home after a week in hospital with influenza.

Confirm the Minutes of the last General Meeting: Minutes taken at the 6th Sept, 2023 meeting, as published in the Nov/Dec., 2023 edition of Ford Torque confirmed as a true and accurate record.

Moved: Alan Bergman. Seconded: Arnold ChiversCarried

Business arising from the minutes: Peter Churchill reports that CPS signatories still to be registered with VicRoads. Michael Gerassimou moved that the business arising from the minutes be accepted. Seconded: Greg Rose.....Carried.

Correspondence Inwards: Usual correspondence from the AOMC with the relevant information passed on to the members as well as their News Bulletin, Country Motor Magazine, CCA's latest Radshell Magazine // Dave Slater has sent me the tickets for the 2 sites the Club has at 'The Bendigo Swap Meet'. // The club is waiting for the Public Liability insurance renewal form to arrive. We are covered in the interim.// The latest AOMC bulletin has just arrived and will be sent out shortly.

Correspondence outwards: Letter sent to Jenny Davies thanking her for donating Laurie Tilley's (her father) collection of Model A Ford books to the library. Kevin Churchill has confirmed our booking for using this meeting room next year with the Kew library.

Rob Rush moved that the inwards correspondence be accepted and that the outwards correspondence be endorsed. Seconded: Mark Wallington.....Carried.

Business arising from the correspondence: Nil.

Treasurer's Report: Peter Churchill reported that the Club is in good shape financially and gave a run down on the balance changes since the last General Meeting in September. Statements are available on request.

Peter Churchill moved that the Treasurer's report be accepted as a true and accurate record. Seconded: Russell Boyle..... Carried.

Past Events Report:

4th – 17th Sept – VDC "Where the Rivers Run Rally" Glenda Chivers related to Members what an enjoyable event this was. 2000 miles travelled on all sorts of roads. 14 cars in total with 7 Model As finishing. Very interesting outback towns and places were visited including Broken Hill, Silvertown, Wilcannia, White Cliffs and Trilby Station. In summary, a great time was had by all.

6th Sept:- MAFCV General Meeting.

10th Sept:- Shepparton Swap.

17th Sept:- International Model A & Memorial Day at Cardinia Reservoir. Charlie Grima reported that an ideal site was spoiled by too many of the general public in attendance.

8th Oct:- Yarrambat Historical Museum open day. Charlie Grima also reported on an interesting day with 3 Model A's, a Model T and a Mustang attending. Fine weather and interesting displays. Another couple of cars next year would be good.

12th Oct:- Mid-week brunch run to Arthur's Seat Eagle Café and then the Car museum. Russell Boyle commented on a

Ford Torque

very successful outing with 17 members in attendance.
22nd Oct:- Ford Flathead Festival at the Scoresby Steam Centre. Peter Churchill gave a rundown on a successful day despite the wet weather. Approx 90 display cars were on site.

Coming Events:

11th-12th Nov:- Bendigo Swap Meet. Our Club has 2 outdoor sites booked and dinner will be booked for Saturday night at the Whitehorse Hotel.

12th Nov:- Historic & Commercial Truck Show At Yarra Glen.

19th Nov:- Shannon's American Motoring Day at Caribbean Park.

26th Nov:- 75th Anniversary of 48/215 FX Holden celebration at Trafalgar Holden Museum

3rd Dec:- Models A&T Christmas Party at Ashburton.

Preparations are well under way with the Model T Club. Raffle prizes always welcome.

6th Dec:- MAFCV Committee Meeting.

2024:-

7th Jan:- Breakfast on the Yarra.

21st Jan:- Festival of Motoring at Cruden Farm. Russell Boyle encouraged members to attend this great day. So that we can enter as a group, a venue to meet at beforehand will be sent to members.

31st Jan:- MAFCV General Meeting.

3rd Feb:- Bendigo Swap at Arkoona Park, Berwick

General Business:

Membership Report: Kevin Churchill related we have 180 financial members with 8 still to pay dues. It was noted that Terry Opie from Charlie's Museum now owns Peta Turnbull's 1930 Model A Fordor Sedan and has joined the our club.

AOMC: Kevin or Rob T. The minutes taken at the AOMC Sat.26th August meeting are included in the Nov/Dec edition of Ford Torque.

CPS: Brenden Wolfe: Happy to continue looking after the Club's CPS permit scheme next year. New signatories are to be added soon.

Ford Torque: Kevin Churchill is always looking for input, photos or articles. Deadline for January/ February edition is 29th December.

Website: Mark Apterman.....Always happy to receive photos for the website.

Library: Please don't lose track of books or magazines you have borrowed from the library. Books donated by Jenny Davies on behalf of her father, Laurie Tilley are now available in the library. Malcolm Mathias has also supplied 2 new books from his sale catalogue.

Clothing & Merchandise: Some men & women's chambray shirts available as are polos and the new rugby tops. Polos - \$36. Rugby tops - \$46. Metal Club Badges \$15.

Other items: In answer to a question from Alan Bergman, Russell Boyle confirmed that our Club is a current Chapter Member of MAFCA. Alan suggests we send out a MAFCA publication, 'A World' to our Membership as it is designed specifically for teenagers.....to be explored.

Cars/ Parts for Sale or Car/Parts Wanted: Charlie Grima is looking for 2 good 19" wheels. Kris Cunningham has a variety of second hand parts in varying condition. Details are in the back of your Ford Torque.

Tonight's Raffle Prizes: Thanks to Mark Wallington and Rob Rush and any other contributors and ticket sellers.

Tonight's Activity: AGM followed by a 'Nibble & Natter' evening.

'Pie Night Supper': Thanks to all those involved in the preparation, especially Brenda for the home made sausage rolls. Next General Meeting: 31st January, 2024.

Meeting Closed: 9:10 pm.

RR

Model A Ford Club of Victoria Inc.A0004008Y

Annual General Meeting (No. 49)

Held Wednesday, 1st November, 2023.

Phyllis Hore Meeting Room, Kew Library.

Meeting opened by President, Rob Turner at 8:40 p.m.

It was established that a quorum of the 309 Membership was present. 34 members present in person, 2 online via zoom and 7 proxy votes to be included. (Quorum required - 31).

Rob Rush was the Returning Officer for the meeting.

Attendees: as per the attached list (34 Members identified as present and 2 zoom attendees).

Apologies: Chris & Sharyn Wells, Geoff Hayhow, Ray and Ann Newell, Bill Bartlett, Gary Mexted, Barry and Liz Hoghton, Merv Swingler, Neville and Pat Seiffert, Peter and Dulcie Lachmund, Peter McMahon and John Aird.

Confirm Minutes of 2022 AGM: The minutes of the 2022 Annual General Meeting, held on the 2nd November, 2022 and printed in the Jan/Feb 2023 edition of Ford Torque were confirmed as a true record of events. Moved: Alan Bergman. Seconded: Michael Gerassimou....Carried.

President's Report: President Rob Turner presented his report based on our Club's activities during the last twelve months. He thanked the Club Members and the Committee for their support and expressed the hope that the future remains positive with running more club events and encouraging members to use their cars as often as possible. Rob noted he will not be available for re-election for any Committee positions due to work constraints.

The Treasurer's Report: Peter Churchill gave a comprehensive report on the Club's finances for the financial year 1/7/2022 to 30/6/2023 and explained that we are in a healthy position. Given the budget projection for 2023/2024, Peter sees no need to increase our Club's annual subscription fees and moved that the current rates remain. Seconded: Alan Bergman.....Carried.

(City Membership with the email version of Ford Torque be \$45 or \$50 with the printed version / Country Membership with the email version of Ford Torque be \$40 or \$45 with the printed version).

Peter moved that the Treasurer's report be accepted. Seconded: Michael Gerassimou.....Carried.

Copies of his report are available by request.

Election of Office Bearers:

Rob Turner was called to chair the elections. Rob, on behalf of the members, thanked the Committee for their efforts during the year. He then declared all Committee positions vacant and noted the Secretary has nominations for some of the Committee positions. He will accept nominations from those attending the meeting and will be asking the membership to extend the time frame that a member can hold a position on the committee, as some members will exceed the 2 years stipulated in the Club's constitution.

Election of Office Bearers cont'd:

President: Greg Rose. Nominated by Russell Boyle. Seconded by John Penhall.....Carried. There being no further nominations Greg was elected President.

Vice-President: Kevin Churchill. Nominated by Michael Gerassimou. Seconded: Peter Churchill....Carried. There being no further nominations Kevin was elected Vice-President.

Secretary: Rob Rush nominated by Sue Rush. Seconded by Brenda Smith.....Carried. There being no further nominations and having served more than 2 years in succession as Secretary, Rob Turner moved that Rob's position be extended to the next AGM. Seconded: Ross Fisher.....Carried. Rob R was elected Secretary.

Treasurer: Peter Churchill nominated by Kevin Churchill. Seconded by Richard Miles.....Carried. There being no further nominations Peter was elected Treasurer.

Resolution to determine the number of Ordinary Committee Members: It was moved by Rob Turner that the number of Ordinary Committee Members be not less than 3 and not more than 7. Seconded Arnold Chivers....Carried.

Ordinary Committee Member Nominations:

Russell Boyle nominated by Sue Rush. Seconded by Rob Rush.....Carried. As Russell has served more than 2 years in succession on the Committee, Rob Turner moved that his term be extended to the next AGM. Seconded by Richard Miles.....Carried.

Brenda Smith nominated by Rob Rush. Seconded by Sue Rush.....Carried.

Mark Dohrmann nominated by Russell Boyle. Seconded: Rob Turner.....Carried.

Mark Wallington nominated himself. Seconded: Charlie Grima.....Carried..

As no further nominations were forthcoming, Rob Turner congratulated the successful nominees and declared the above Committee positions filled.

There being no further business, new Club President, Greg Rose thanked Rob Turner for chairing the AGM and everyone who participated.

The following Members were also thanked for their ongoing commitment to the Club:

Ford Torque – Kevin and Erica Churchill.

Ford Torque Distribution – Rob & Joan Griffiths.

Club Delegates – Rob Turner & Kevin Churchill.

Webmaster – Mark Apterman.

CPS – Brenden Wolfe.

Librarian – Sue Rush.

Merchandise – Sue Rush and Faye Gillson.

Zoom co-ordinator – Geoff Hayhow.

Supper Roster and Ticket Sellers – Joan Griffiths, Faye Gillson, Brenda Smith, Helen Bell, Glenda Chivers and Annette Moodie. We also acknowledge and thank Faith Hayhow for her many years helping prepare the suppers.

Meeting Closed: 9:10 pm.

RR

OIL FILTERS

Richard Miles has supplied the following YouTube link showing how the valve cover oil filter kit actually works inside the engine comparing hot and cold oil.

<https://www.youtube.com/watch?v=9YXjaxxC7rE> There is a follow up video at:

<https://www.youtube.com/watch?v=2cokwOBOW4&t=45s>

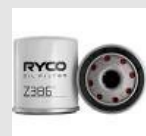

Thank you Richard

THE MODEL A TOOL BOX

COTTER PINS (Split Pins in Oz)

By Colin Lawson - Canada Capital A's

There are approximately 163 cotter pins used in the Model A. This was an easy way to secure fasteners and prevented nuts from becoming loose. It was also a preferred method where items were frequently disassembled for servicing. It is important that replacement pins be installed in the correct way. Our member Dave Welch, being a former heavy equipment owner/operator, declares only to use new cotter pins for replacement to save your life.

While doing a wheel alignment check on a member's car a glaring problem was evident. The engine mounting plate on one side was loose and on its way to falling off. Two nuts were missing, one bolt was captured by the rubber mount and the other bolt was sheared off. All because no cotter pins were installed on both mount plates when the float-a-motor kits was added. Also note in the picture that one securing bolt of the side mount spare bracket is missing or was never installed. The engine mount was removed and original bolts and nuts were installed with new cotter pins on both sides.

When a Float-A-Motor kit is installed, the nuts go in farther on the bolts since the inner rubber pad is removed. Flat washers should be installed under the nuts to ensure the pin hole is closer to alignment with nut grooves so the cotter pin grabs properly. The nuts should be suitably torqued to secure the mounts. The original bolts are 5/16 x 24 so a typical torque is 20 ft-lbs.



Loose engine mount side plate

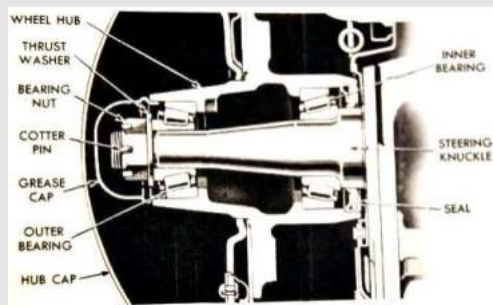

Alternative "tuck" method to bury the ends as used in parasail and some aviation equipment, but the pin head is not secured in the castellation.

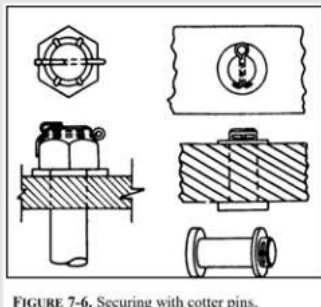

FIGURE 7-6. Securing with cotter pins.

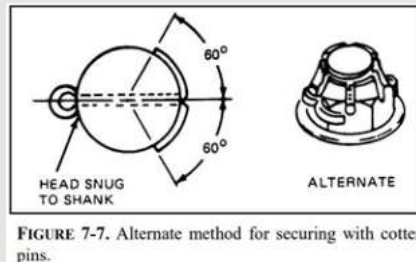
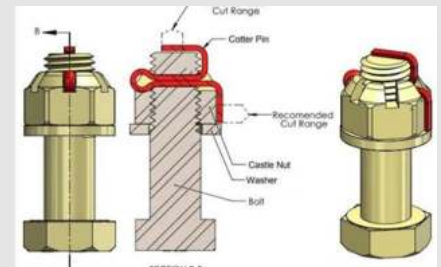

FIGURE 7-7. Alternate method for securing with cotter pins.

For locations such as clevis pins and shock links the cotter pin is placed as shown in Figure 7-7.



Information from FAA advisory circular (AC 43.13-1B):

- Cotter pins are used to secure such items as bolts, screws, pins, and shafts. Their use is favored because they can be removed and installed quickly.
- The diameter of the cotter pins selected for any application should be the largest size that will fit consistent with the diameter of the cotter pin hole and/or the slots in the nut.
- Cotter pins should not be reused (on aircraft).
- A finished cotter pin installation should be tight. Loose installations can cause premature wear and failure.
- When using the method of cotter pin installation as shown in figures 7-6 and 7-7, ensure the prong, bent over the bolt, is seated firmly against the bolt shank, and does not exceed bolt diameter. Also, when the prong is bent over the nut, ensure the bent prong is down and firmly flat against the nut and does not contact the surface of the washer.

Maybe amusing, but first thing I noticed was that most cotter pins were replaced with either 4d or 6d nails. During this period, (with Cokes & candy bars selling for 5 cents), lots of local Model A's, as I remember during these times, were owned by families who were so poor that they made their own boxer shorts from scratch with multi-colour flour sacks & buttons because they could not afford to buy the more expensive elastic type Hanes Underwear.

An observation from Mr Chavin on FordBarn: When I bought my 1930 Coupe in 1958 for \$25.00, there were 3 or 4 other Model A's parked on the side of our rural gravel roads in the \$60.00 range.

FOR SALE

1930 Steering Wheel in good condition
\$35
Contact John Spragg

0414
662



622

FOR SALE

LHD Bell housing excellent condition
\$325

John Spragg 0414 622 662



1929 Tourer

Engine # CA 147822

Reconditioned Engine, good hood.

Paint may need attention.

Needs Upholstery

Reliable vehicle converted to 12 volt.

Portland area

\$22,500

Phone Lindsay Kennett

0403 645 218

FOR SALE



FOR SALE

RH Drive Bell Housing.

Single plate clutch, original cast iron, no cracks, not seized. Pick up only. You will need this if changing from left to right hand drive. \$325.00

Please call John Spragg; 0414 622 662



WANTED

For a 1928/29 Coupe/Roadster -

Rear guards & support arms;

Curved panel that goes above the rear window;

Boot lid hinges NOT dickie seat hinges; Boot lid handle;

Condition not critical as long as they are reasonable and haven't been run over by a tractor. Dave Canavan 0417 924 835

01/24



1931 Two Door Phaeton and 1929 Taxi at the
AOMC American Motoring Day 2023



Two 1928 Tourers at Yarrambat Heritage Museum